

ET Series

ETR800Series
Temperature Sensors for I/A

Wiring Diagram for all 2-wire Resistive Room Temperature Sensors

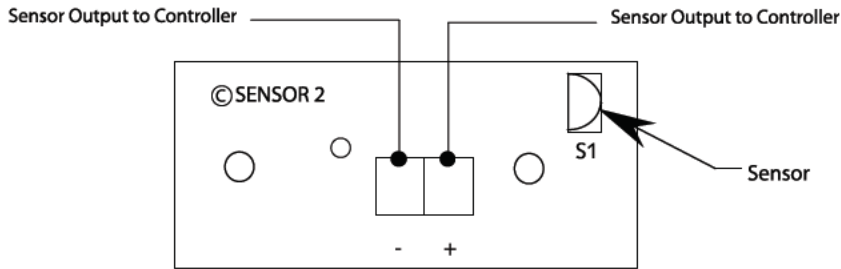

Room Temperature Sensor for I/A with Override Switch

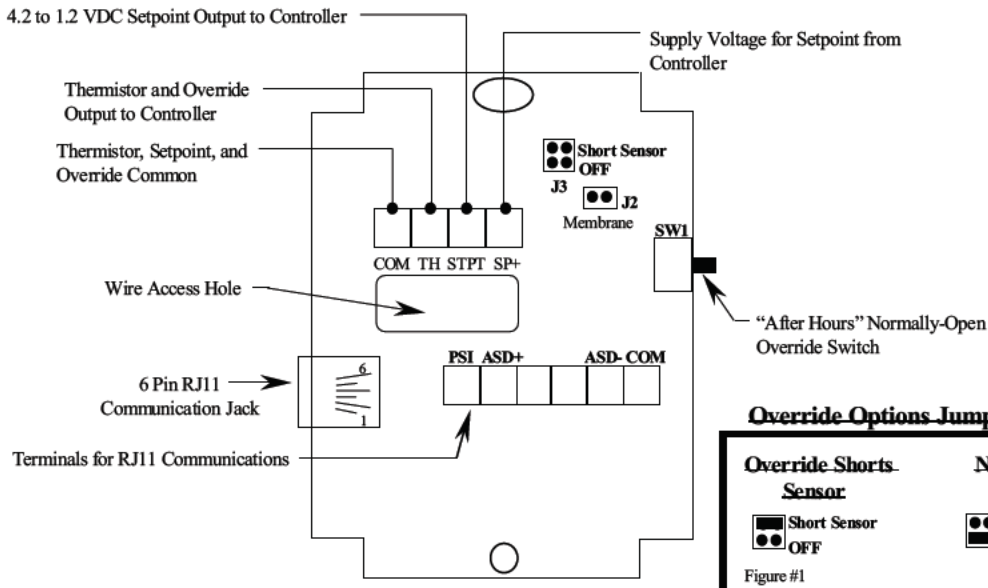

Override Options Jumper Settings (J3)

Override Shorts Sensor	No Override
Short Sensor OFF	Short Sensor OFF

Figure #1

Room Temperature Sensor for I/A with LCD

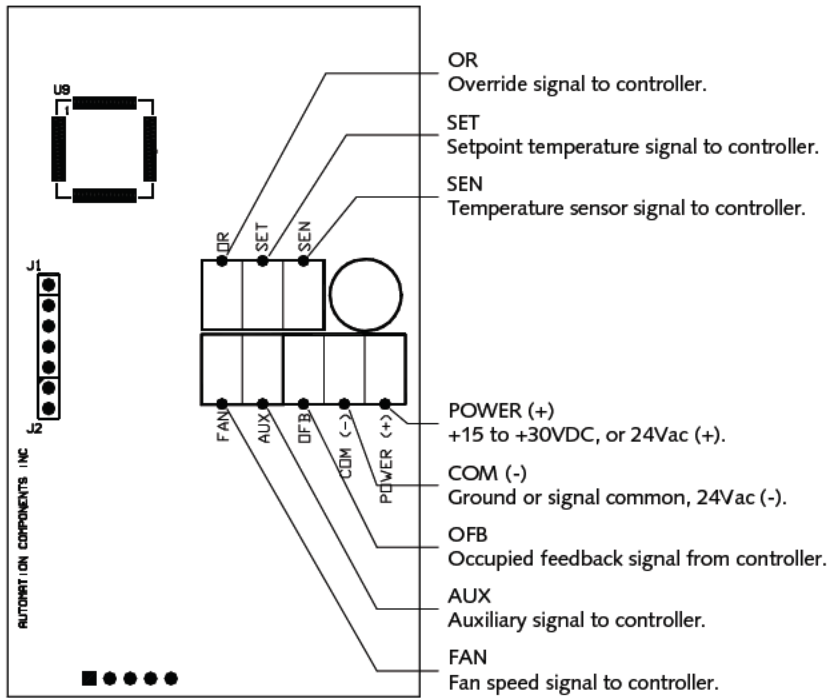

On October 1st, 2009, TAC became the Buildings business of its parent company Schneider Electric. This document reflects the visual identity of Schneider Electric, however there remains references to TAC as a corporate brand in the body copy. As each document is updated, the body copy will be changed to reflect appropriate corporate brand changes.